

**3D Printing Preparation.**  
**The 3D Printer is located in the Solid Space Fabrication and Prototyping Lab.**  
School Of Interactive Arts And Technology.  
Simon Fraser University, Surrey.  
Room 3702. Card key access.

Estimates/Bookings:  
3d\_print@sfu.ca

Disclaimer:  
Solid Space cannot guarantee jobs will be completed by deadline dates. If work is needed urgently you may need to make other arrangements.  
Solid Space cannot be held responsible for incomplete or poorly designed projects.

## 1.0 Introduction to the 3D Printer in Solid Space Lab.

How it works:

The **Stratasys Dimension SST 1200es** 3D printer creates plastic physical models from three-dimensional CAD model data, using what's known as a Fused Deposition Modeling (FDM) process. The plastic is an ABS derivative.

The proprietary printer software breaks the CAD model into individual sections, with each section representing one layer of material. It uses this data to drive an inkjet type print-head to deposit a hot liquid ABS plastic filament in the small layer increments, building up the Z-axis. This cools and hardens on a special modeling base. The model has to be removed from this later.

While building the model, the printer also generates a secondary type of material, the **support material**, that acts as a scaffolding to support the part as it is being built. This is something that needs to be kept in mind as parts with long overhangs or peculiar configuration may use a lot of this material, which adds time and cost to the print. Depending on the part design, the addition of the support material may mean a decrease in the allowable part size. The support material is dissolved in a special bath after printing, hence the term SST- Soluble Support Technology. This dissolving can take as long as a full day depending on the amount generated by the printer.

Shown are pictures of models with support material:



As from <http://www.shapeways.com/blog/uploads/shapewaysrv4.JPG>



[http://www-cdr.stanford.edu/DML/tele\\_projects/page\\_graphics/fingerRingFDMwSprt120.jpg](http://www-cdr.stanford.edu/DML/tele_projects/page_graphics/fingerRingFDMwSprt120.jpg)

ABS plastic is a durable material that will withstand usage testing, and can be sanded, painted, or post processed in other manners. This is excellent for generating usable prototypes. However, this process is not suited to parts with thin walls, very small or very intricate features. The printer can also print different colours, although not within the same part.

## 2.0 On Using the 3D Printer, Modelling and Exporting Your Part.

Before modelling your part, consider if the printer is the optimum method to produce your part. The 3D printer software, CatalystEX , only takes CAD data in one file format.

That is:

- .STL file format, so ensure you are using the right software.
- See details in the .STL section.
- It is best to set up your files and work in inches.

The maximum size it can build to is:

**10IN X 10IN X 12IN (254 X 254 X 305MM) IN 0.010" TO 0.013" STEPS (RESOLUTION) OR 0.245MM TO 0.33MM. Parts can be NO THINNER THAN .013" (.33MM).**

The minimum turnover is 2 days, not including the time it may take for an appointment and verification.

Parts must also be designed for the 'real world', for example, it should hold its own weight and balance if it needs to stand. Again, due to the printer's resolution, thin walls or fine text may not print or turn out poorly. Parts with small gaps or spaces may not print or turn out poorly as well.

Shown is a picture posted from Shapeways (an online fabrication service and forum) that illustrates the limitation of some of the 3D printing processes, including FDM. This is an excellent resource for further investigation of 3D printing technologies.

Credit : Rob Mack

[http://www.shapeways.com/forum/index.php?t=msg&goto=1658#msg\\_1658](http://www.shapeways.com/forum/index.php?t=msg&goto=1658#msg_1658)

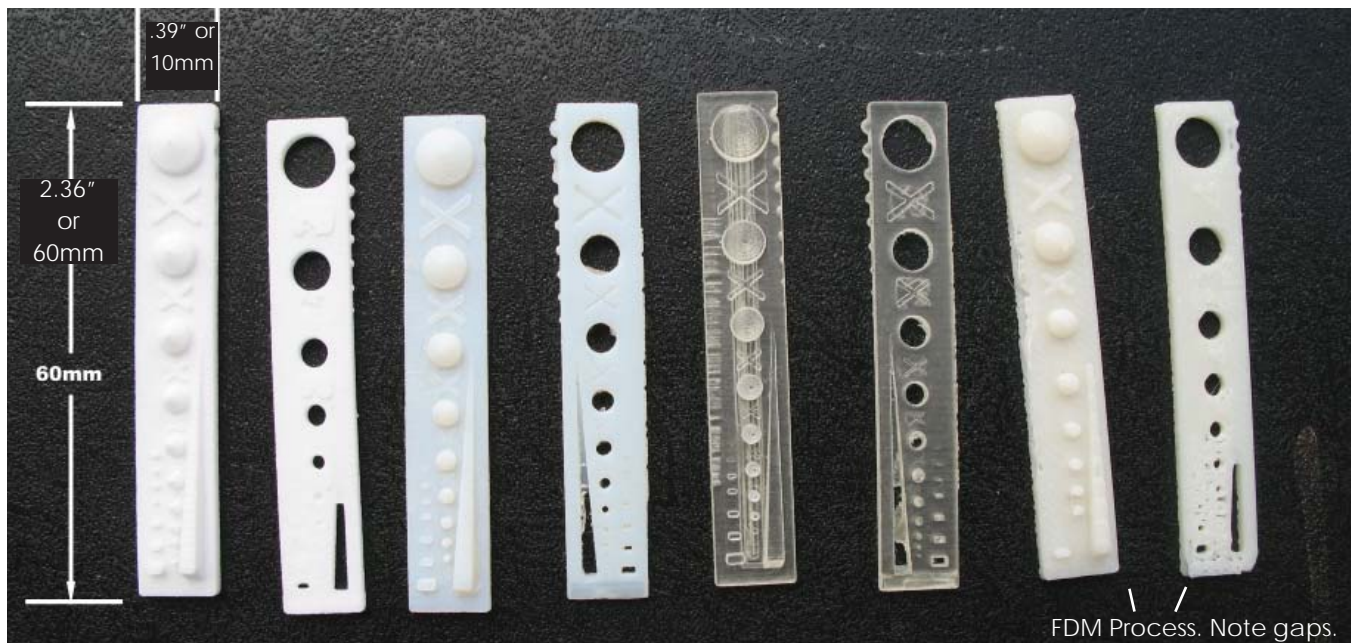

Consideration should also be given to how the SST dissolving bath will interact with the design of the part to dissolve support material in an efficient manner.

When to use a 3D printer:

- Complex 3D objects, such as organic, curved shapes.
- Generating low to medium fidelity, usable, accurate prototypes.
- When traditional hand and power tools cannot achieve the required results.

Specific Advantages of SST 1200es 3D printer FDM process:

- For small quantities, it is faster and cheaper than outsourcing for mold making.
- It offers great flexibility in creating complex 3d objects with internal components built in.
- Parts can withstand use and post processing options, such as being cast, or being sanded and then electroplated.
- Parts are dimensionally stable.

Specific Disadvantages of SST 1200es 3D printer FDM process:

- Minimum 2 day turn around times, excessive SST dissolving time, etc may add to this.
- Only 1 type of plastic material used- an ABS derivative.
- Not practical for higher quantity production, may not be cost effective for certain parts.
- Resolution is not very fine and it does not produce a smooth surface.
- Post processing (sanding) may be needed

## 2.1

### STLS and 3D Printing.

Since most of the applicable classes at SIAT use Solidworks, it is assumed this is what the designer will be using this to generate print models. As such, this document will address the general issues with that. Of course, print ready models can be generated with other programs.

No matter the program, you will need figure out the dimensions and scaling of your model, while respecting the limits of the build envelope and the process. You will need to export your model to .STL format, which is what the 3D printer software requires. Most programs will export to STL directly. Some may require an add-on or other software.

The .STL format is a standard rapid prototyping/CAD industry format. It is comprised of a raw 'dumb' triangle mesh, supporting no features or colours. The number and size of these flat triangles faces define the mesh, so its important there are enough to accurately reproduce your design.

The number of triangles created to define the .STL mesh can be user modified in the modeling software. In Solidworks this under the .STL export options as 'Resolution' (further refined through the 'deviation' and 'angles' settings). See **Section 3.0** for more details. A large number of triangles means a detailed, smoother model, but can mean a much larger file size. Be aware of this trade-off as well as how it ties in the resolution limitations of the 3D printer.

The .STL format has technical issues the designer should be aware of. To quote a 3D printer manufacturer *"The .STL format allows much and guarantees little; simply exporting to the .STL format in no way guarantees it's printability."* These issues are not all covered here.

Importantly, the .STL file must also be closed and 'watertight'. With Solidworks this means no bad geometry or modelling (things like missing caps or fillets). A very quick (although not comprehensive) way to check is to:

- **Re-import the .STL back into Solidworks. SW will give you errors if there are problems.**
- **If you have the CatalysEX software then you can also import the .STL into that to check. Problem files will not undergo .STL 'processing' or be 'added to the pack'.**

Modeling in Solidworks will in itself lessen some pitfalls but it can still output bad parts. In other words, the

designer still needs to double-check that the part is designed correctly, such as having the right part/wall thicknesses, etc. Again, it must be adhere to 'real-life' and 3D printer limitations.

As for invalid geometry, it does need to be noted that other 3D programs may often allow geometry mistakes to exported, such as self-intersecting triangles, open volumes and other errors. Many software utilities exist for addressing these problems, that also import various file formats and generate .STL format.

As mentioned, getting into the nuances of building good meshes, STL meshing, exporting, and error checking is beyond the scope of this document, but there are excellent resources online devoted to this. Ask Lab staff if you have any specific questions.

Note that the .STL file itself cannot be easily modified to any great extent.

### 3.0 File Requirements for 3D Print Submissions:

File Types:

**.STL files is only accepted format.**

**If not in this format, it will not be printed.**

**File Parameters:**

All files must be set up to scale, inches\*, and within the build envelope previously mentioned.

**If your file exceeds the envelope, it will not be printed.** Keep in mind a model just fitting in the envelope size may not build due to support material requirements.

**Very large .STL files, at 50mb + may not be printed**

**Files submitted by classes should be much less.**

**Lab technicians are not responsible for reformatting or remodeling files.**

In the Solidworks menu, go to 'Save As'. Select '.STL' from the 'Save As Type' drop down under the file name.

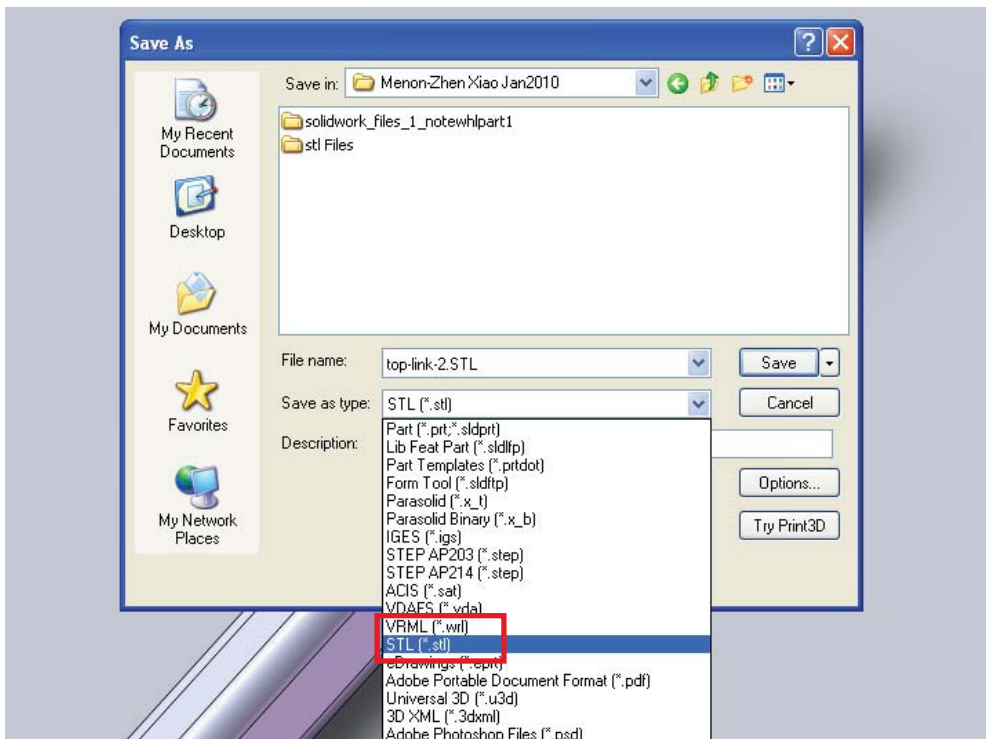

\*why?: For consistency reasons. Most of the lab machinery is American and uses imperial. Although the CatalystEx software does deal in metric and imperial, final pack volumes, material needs, modeling cost estimates, are done in imperial.

When exporting from Solidworks ensure your resolution, and other parameters are set appropriately for your purposes. This will be under the 'Options' button once you have selected the .STL format under 'Save as'. You will save your file **in inches** and as a **binary .STL**.

Set the resolution to 'fine' or 'custom' depending on your needs. 'Fine' will suffice in most cases. Smoothly curved surfaces (like a sphere) may require higher resolutions to eliminate faceting.

Do not export entire assemblies or packs in a single .STL file as they may fuse when printing. For actual working assemblies that you wish to print as one file, please consult with Lab staff before hand.

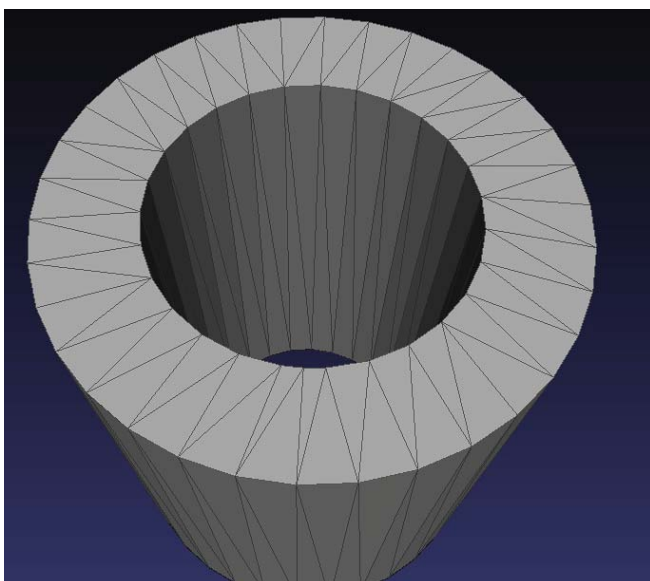
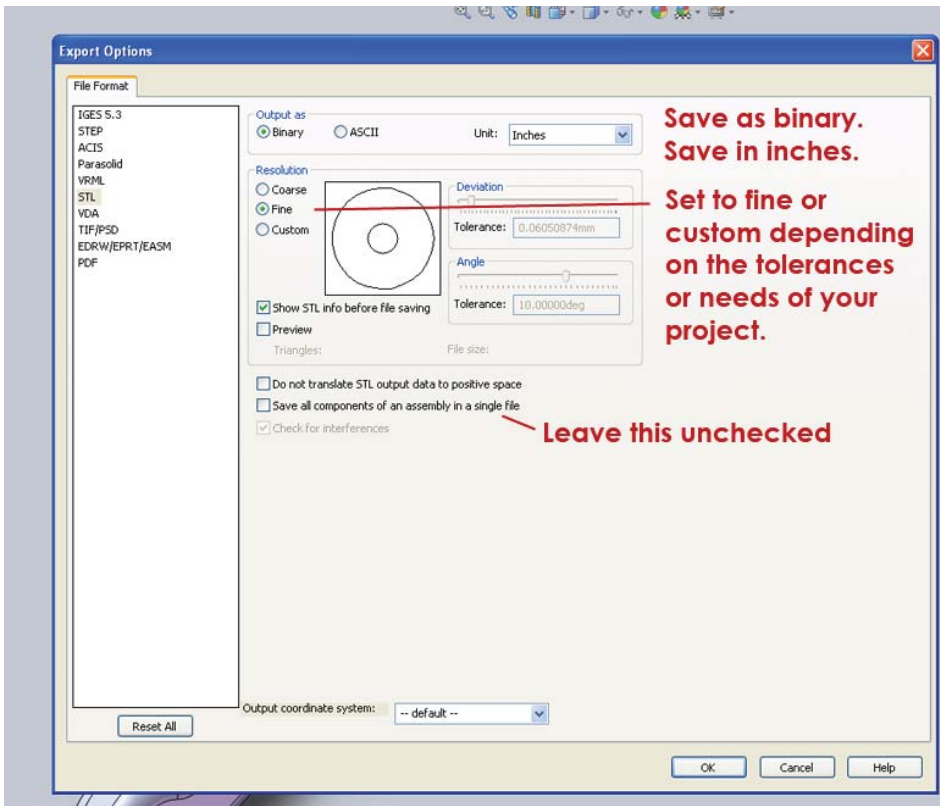

Coarse .STL settings- too rough. Note 'flat' edges.

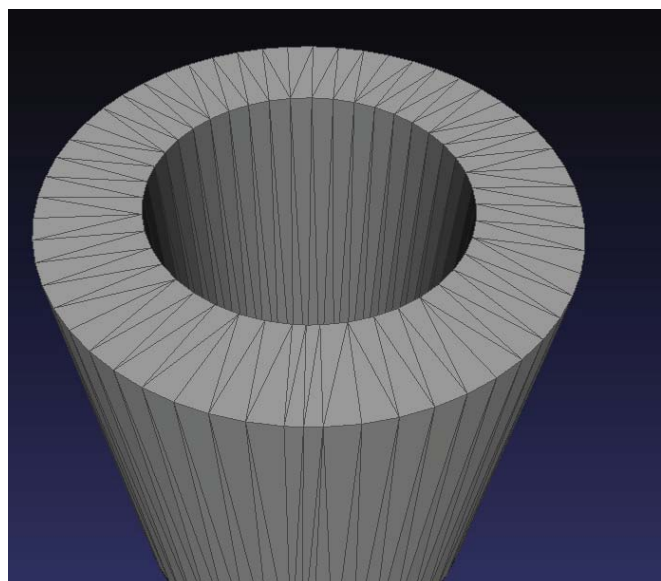

Fine .STL settings- good without the file being too large.

Some SIAT courses may offer a 3d printing preparation component as part of their course outline. As such, you have the option to submit prepared packed .cmb.gz file created by the Stratasys program CatalystEx. Ask your instructor or The Production Technologist for more information.

#### 4.0

#### **Getting the Files Processed: Steps to Submit 3D Files for Printing for SFU Graduate Students and Faculty at SIAT, and Outside SIAT.**

All SFU Graduate Students and Faculty that require use of the 3D printer will be charged for their parts. All Graduate students will need to have an research or department fund account number ready prior to contacting staff for an estimate. If you are unsure of what the account number is, discuss with your supervisor or Professor.

#### **Name your files: FirstName\_LastName\_\_ModelTitle\_Date**

Email a request for an estimate, **with** the files (if size allows) **or** the **link to the files**, in the right naming convention, as outlined above, to:

3d\_print@sfu.ca including:

Student First and Last Name:

Student Department-Project type:

File Name:

Account Number:

How many prints are needed of each model. (ie 'I need 2 copies of model part A').

Note:

You can also send email to the Production Technologists, and Technical Assistants, personal SFU email addresses.

**You can also e-mail for an appointment to physically drop off the files on a USB stick.**

Keep in mind, that no guarantees can be made of when the files will be processed until the Lab technician looks at the files.

Estimates are based on the volume of **all** material needed per part, plus a set-up fee. We need the STL files and part counts to expedite your estimate.

Once you receive your estimate via e-mail, **you will need to verify it's ok**, and then printing will proceed in the order it was received.

Once parts are ready, staff will let you know. Please ensure a pick up time is confirmed prior to showing up at the Lab.

#### 4.1

#### **Getting The files Processed: SIAT Undergrads with Applicable Classes.**

You will need to set a booking for printing before (or as you are) submitting your file through your TA or instructor. Please allow advance notice. Submission procedures may vary by classes.

As you will be dealing with your TAs to coordinate printer booking and file submission, they will help ensure your files are ready. TAs or Instructors will need to communicate with the class and ensure the files adhere to file format and .STL integrity guidelines **before setting bookings for students to come to the Lab to print.**

Once you go to print your file in Solid Space, it must be 'ready to go'. Files will be printed in sequence so the earlier you get it in, the earlier you get it out.

Depending on class demands, printing may be conducted in batches. The timing of batch prints, if applicable, will be communicated to your class through your TA or instructor. When completed, you will receive an e-mail, or your TA will be notified.

The file itself should be named:

**FirstName\_LastName\_\_ModelTitle\_Date\_Class**

Note the number of parts needed (ie 'I need 2 copies of model A')

Cut off days will be established before the end of term to ensure parts are done before review.

#### 5.0

#### **Pricing for SFU Graduate Students and Faculty at SIAT and Outside SIAT.**

##### **SIAT Grad Students and Faculty:**

The cost of 3D printing is based on the cubic inch of modeling material plus support material used.

- **The current rate is \$6.00 per cubic inch plus a \$30.00 set-up fee.**

You can calculate the volume of an object in Solidworks to get an approximate idea of the costs, but this would not include the costs of the support material and set-up fees.

##### **SFU Grad Students and Faculty (Outside SIAT):**

- **The current rate is \$6.00 per cubic inch plus a \$45.00 set-up fee.**